

AI powered automatic toll payment system using Number Plate Recognition

Bugatha Renuka B.Ramamohan

Department of Electronics and Communication Engineering
Lendi Institute of Engineering and Technology, Jonnada(Village), Vizianagaram – 535005, INDIA
Corresponding Author: renukabugatha1111@gmail.com

ABSTRACT

In this paper, the author has suggested a contactless toll collection system, which employs Artificial Intelligence (AI) and Number Plate Recognition (NPR) to enhance efficiency at the toll plazas. The system will be constructed under Raspberry Pi with a USB camera which will capture pictures of the vehicles in real time. A deep learning model based on the YOLO system detects the license plates and the vehicle numbers are recognized through the Optical Character Recognition (OCR). A sensor in the ultrasonic mode detects the coming vehicles and the automatic toll processing and the opening of the gates with the help of a DC motor and a driver. A database stores vehicle-related information and account balances, and the deduction of tolls can be done automatically. Status of transactions is displayed on an LCD screen, and a buzzer is used to notify the user about any errors or confirmations. Experimental findings indicate that the system is reliable to use, highly accurate and lessens congestion, delays and manual work, which is very economical as compared to traditional method of collecting tolls.

Keywords: Number Plate Recognition, YOLO, OCR, Raspberry Pi, Automated Toll System.

I. INTRODUCTION

Increased number of vehicles in roads has led to delays and congestion in toll booths. The traditional manual toll collection involves human operators, which will lead to long queues to collect tolls, high use of fuel, and the likelihood of errors.

The solution is automated toll systems. With the use of AI and embedded systems, one can create a smart system that would be able to recognize vehicles. Specifically, with the help of the deep learning and Number Plate Recognition (NPR), real-time license plate recognition can be performed with reasonable confidence. The use of low-cost hardware such as Raspberry Pi means that it can be adopted on a low cost whilst still performing well.

In this paper, an AI-driven toll collection system is provided, in which the license plates are detected through a YOLO model and the vehicle numbers are read through OCR. An ultrasonic sensor controls vehicle detection and a DC motor and driver control gate control. A database is used to monitor vehicle data and account balances and allow toll fees to be deducted automatically. The primary objective is to minimize traffic flow and congestion, minimize human touch, and enhance effectiveness in toll collection.

A. Problem Statement

The current methods of toll collection, such as the use of the manual cash collection and RFID, tend to cause traffic jam and excessive waiting periods. RFID solutions impose an additional cost and user compliance, which might raise the cost and decrease the convenience. To simplify the process of collecting tolls a cost efficient, fully automated system capable of detecting vehicles in real time without the inclusion of additional equipment is hence required.

B. Contributions

- Created a Raspberry Pi-based Toll collection system at low cost and with AI capabilities.
- There is an integrated model of YOLO that can detect the license plate fast and precisely.
- Extracted vehicle numbers by using OCR.
- Deduction of tolls that are done automatically by linking the system to a vehicle database.
- Gave real time feedback through LCD and buzzer alerts.
- Less human intervention and traffic congestion, enhancing performance of the systems.

II. LITERATURE SURVEY

The automatic license plate recognition (ALPR) systems will be usually a challenge because of light, noise and plate format variations. Accurate feature extraction and character recognition on vehicle plates are done using Convolutional Neural Networks (CNNs). In order to improve the precision, the Regular Expressions (RegEx) are used to check and fix the identified text according to standard formats. The integrated solution enhances the reliability of recognition and is applicable to the real-time traffic and toll control programs [1].

LPR in complex scenarios is a challenging task because of the scarcity of labeled data, changing light conditions, and occlusions as well as varying plate format. The strategy presents a few-shot learning model that uses a lightweight model to facilitate effective recognition using limited training samples. The system uses the small deep learning architectures to minimize its computational complexity and maintain high accuracy, rendering it resource-appropriate devices. The experimental results show better performance and robustness in the real world conditions which favor reliable use in intelligent transportation systems [2].

Automated parking and toll management systems must be handled with efficient vehicle identification. This method involves a YOLO based deep learning framework

that is used to efficiently identify and cut license plate areas in vehicle pictures in the real-time scenario. The vehicle number is then retrieved using Optical Character Recognition (OCR) and generates automated toll or parking fees. The system promises to be fast, highly detective and easily integrated with smart parking infrastructure meaning that it will provide a trusted and non-contact way of ensuring intelligent transportation uses [3].

The present paper outlines a sophisticated method of license plate recognition and automated toll/parking system management by deep learning methods. The system uses a YOLO-based configuration to achieve accurate and real-time vehicle license plates detection in different environmental conditions. The Optical Character Recognition (OCR) is used to obtain the alpha numeric information in the vehicle plates that have been detected, and the vehicle can be identified as well as fees can be processed automatically. The given approach is aimed at enhancing the accuracy of detection, minimizing the complexity of the calculations, and providing sound performance under the real-life conditions. The findings indicate that the system is an efficient, scalable and contactless transportation and smart parking application system [4].

This paper proposes a virtual toll booth, which uses Number Plate Recognition (NPR) to collect tolls automatically and contact free. The system makes use of YOLOv8 that does a good and real time detection of vehicle license plates even in a harsh environment. Alpha numeric characters on the identified plates are extracted with the help of EasyOCR and this allows to identify the vehicle reliably. The data is extracted and combined with a backend system that processes the toll automatically, therefore decreasing the number of people handling this task manually and minimizing traffic jams. The suggested solution is very accurate, efficient, and appropriate to the intelligent transport systems of today [5].

The work offers an independent vehicle identification and tracking system with the help of number plate detection algorithms. The system uses sophisticated image processing and deep learning techniques to autonomously identify and extract license plate data on video stream moving frames in real time. Different locations are tracked and monitored using extracted data to track and monitor vehicles at all times. The method guarantees accuracy and reliability at different conditions in the environment, and this makes it applicable in using it in traffic surveillance, security control and intelligent transportation system [6].

This paper outlines a self-driving toll payment system, which is performed by recognizing the number plates with the help of YOLO and Convolutional Neural Network (CNN). YOLO model is applied in detecting vehicle license plates in real-time and CNN-based methods improve the accuracy of feature extraction and character recognition. The system allows automatic vehicle recognition and automatic toll deduction without any human intervention. The suggested method will enhance

efficiency, decrease traffic jams, and predictable performance in smart transport systems [7].

In this paper, the author proposes a system of vehicle recognition using number plates that will involve the use of number plate recognition in automated toll collection to enhance efficiency in transportation systems. The suggested solution involves the use of image processing and machine learning to identify the vehicle license plate to use as a form of identification. The system allows automatic deduction of tolls through the connection of vehicle information to a back-end database and decreases the necessity of human interference. The researchers point out that the study has improved the accuracy, lessened traffic congestion, and increased reliability and is applicable to intelligent transportation in real-time [8].

The article introduces an AI solution to detecting license plates automatically with deep learning methods. The system uses convolutional neural networks to precisely recognize and spot license plates in vehicle pictures even in different environmental conditions. It also guarantees strong functioning when there is noise, change in lighting, and complicated backgrounds. The suggested approach increases the accuracy of the detection and processing speed that is why it can be used in real-time to monitor traffic, security systems, and automated collection of tolls [9].

The given work introduces an automated algorithm of helmet-free riders detection and number plate recognition at the same time with the usage of deep learning. The system uses the computer vision algorithm to detect the motor flies and identify whether they use the helmet based on the real-time video feeds. Where violation occurs, the license plate gets identified and the vehicle details retrieved to take up enforcement measures. The suggested solution enhances road safety surveillance, allows implementing traffic regulations automatically, and providing intelligent transportation with high precision and real-time functionality [10].

III. EXISTING SYSTEMS

The existing systems of toll collection have been mostly based on manual cash collection or RFID based systems. Manual toll booths make cars to stop which forms long queues and wastes fuel as well.

RFID systems can be deduced automatically however they demand tags, alignment, and some other infrastructure. They may be subject to interference, maintenance and non-conformance by tagless users. The approaches are not very flexible, scalable, and fully automated and drive the desire to have an AI-based solution capable of identifying vehicles and registering a toll without a human is involved.

IV. PROPOSED METHODOLOGY

The developed system is based on AI and NPR to receive real-time contactless tolls. A USB camera takes the vehicle images when an ultrasonic sensor captures an oncoming vehicle. YOLO identifies license plate and OCR identifies vehicle number. To automatically deduct the toll,

the system compares the vehicle information and balance in a database. The motor is a DC motor that is driven through a motor driver. A LCD shows the transaction details and a buzzer is used to give alerts. The method is cost-effective, efficient, and can be scaled to minimise delays in the traffic and human labour.

A. Image Acquisition and Vehicle Detection

The proposed system makes use of a USB web camera and a Raspberry Pi to take real-time images of the vehicles coming to the toll gate. A sensor is an ultrasonic type that is used to determine the presence of a car and initiate the process of capturing an image. This will have the added advantage of making sure that only relevant frames are processed making the computational load less and the system more efficient.

B. License Plate Detection and Recognition

Images obtained are analyzed through a deep learning model based on the YOLO to precisely identify the license plate area of the vehicle. After the detection, Optical Character Recognition (OCR) technologies are used to isolate the alphanumeric characters of the license plate. This allows identification of vehicles automatically without the use of extra equipment like RFID tags.

C. Data Processing and Toll Deduction

The vehicle number that was extracted is compared with database (Excel sheet) entries of vehicle and account balance. When the verification is successful, the amount of the toll is deducted automatically in the balance of the user. The user is made aware and transparency is provided by presenting the transaction status on an LCD screen.

D. Gate Control and Alert System

On the basis of successful payment of the toll a DC motor is operated by a motor driver which in turn opens and closes the toll gate automatically. The audible alerts to successful transactions or the occurrence of mistakes like inadequate balance or unknown vehicles are provided by a buzzer. This forms the smooth and secure working of the toll system.

E. Mathematical Mode

- Vehicle Detection $d \leq d_{threshold}$
- License Plate Detection $B = YOLO(I)$
- Number Recognition (OCR) $N = OCR(B)$
- Toll Deduction $B_{vnew} = B_v - T_{fif} B_v \geq T_f$
- Overall System Accuracy $Es_{ys} = AYOLO \times AOCR$

F. Block Diagram

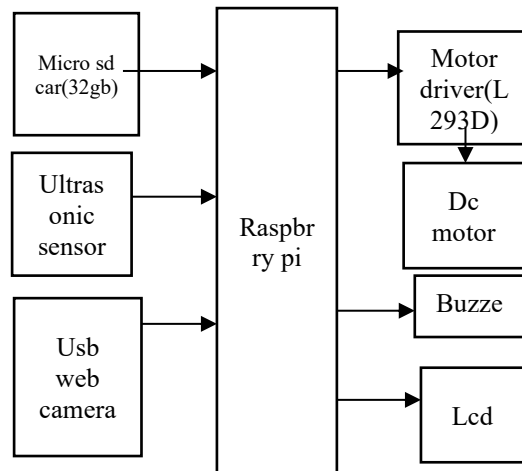

G. Sensor Functionality and Alerts

Component	Purpose	Role	Output	Performance
USB Camera	Captures vehicle images	Provides input for plate detection	Image frame to processor	High
Ultrasonic Sensor	Detects approaching vehicles	Triggers image capture	Signal to Raspberry Pi	High
YOLO Model	Detects license plate	Locates plate accurately	Processed detection	Very High
OCR	Reads plate number	Converts image to text	Text output for database	High
Raspberry Pi	Controls system	Executes detection, recognition, decisions	Commands all modules	Very High
Database	Stores vehicle info & balance	Enables verification & toll deduction	Data read/write	High
DC Motor	Controls gate	Opens/closes gate	Mechanical action	High
Motor Driver	Drives motor	Translates control signals	Motor control	High
LCD	Displays status	Shows vehicle & payment info	Visual output	High

Buzzer	Provides alerts	Indicates success/failure	Audio output	High
--------	-----------------	---------------------------	--------------	------

	and computational resources [2][6]	time deployment in toll systems
Overall Performance	High accuracy but limited system-level integration [1][7]	High accuracy with complete system automation and real-time efficiency

TABLE I.
COMPARISON OF EXISTING SYSTEMS VS PROPOSED IOT + RANDOM FOREST SYSTEM

Feature Parameter /	Existing Systems (Ref.)	Proposed AI-Based Toll System
Detection Technique	CNN, YOLO, and hybrid deep learning models used for plate detection [1][3][7]	YOLO-based real-time license plate detection with optimized performance
Recognition Method	OCR and pattern correction techniques such as RegEx applied [1][5]	OCR-based number extraction with improved real-time accuracy
Data Requirement	Requires large datasets or few-shot learning for training [2][9]	Works with pre-trained models and real-time captured data
Real-Time Capability	Some systems support real-time processing but with computational constraints [3][6]	Fully real-time processing using Raspberry Pi and optimized algorithms
Automation Level	Partial automation (detection and recognition only) [4][8]	Fully automated system including detection, recognition, and toll deduction
Hardware Integration	Mostly software-based or limited hardware implementation [6][9]	Integrated hardware system (camera, sensor, motor, LCD, buzzer)
Application Scope	Used in parking, surveillance, and tracking systems [3][6][10]	Specifically designed for automated toll collection and smart transport
Accuracy Improvement	Uses techniques like CNN optimization and RegEx correction [1][2]	High accuracy with combined YOLO + OCR and controlled environment
Alert Mechanism	Limited or no alert system in most models [8][9]	Real-time alerts via LCD display and buzzer
System Cost	May involve high computational and infrastructure cost [2][7]	Low-cost implementation using Raspberry Pi and basic components
Scalability	Moderate, depends on dataset	High scalability for real-

V. RESULTS

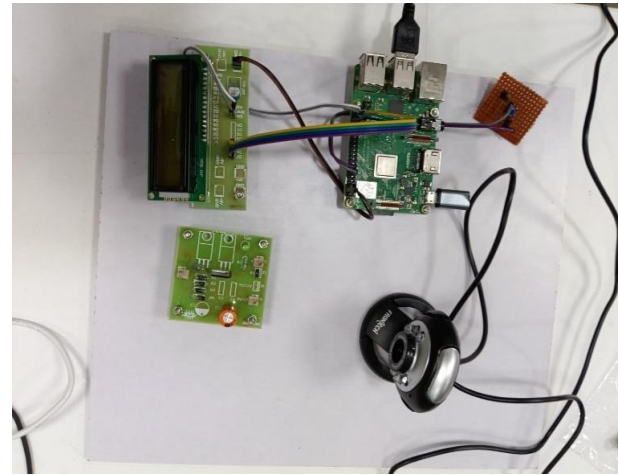

Fig.1. Hardware Setup of Embedded Vision-Based Monitoring System

The graphics display a small, integrated system that comprised of a single-board computer, a camera, LCD display, and a sensor module. The system is able to acquire visual data and process it and present the output in real time. Every piece is interoperable and has the ability to be powered through the USB, which would be appropriate in monitoring and automation.

VI. CONCLUSION

The present paper introduced an automatic toll payment system, which is based on AI and Number Plate Recognition (NPR) as a tool of efficient and non-contact toll collection. A YOLO-based model combined with OCR allowed the implementation of the car recognition system accurately and in real-time, whereas the utilization of a Raspberry Pi allowed keeping the implementation inexpensive and small. Automation of the deduction of tolls, vehicle detection, and gate control within the system minimized the processes of human participation and traffic jams. The experimental outcomes confirmed good performance, high accuracy and enhanced processing speed that is why the system can be implemented in practical use in intelligent transportation systems.

FUTURE SCOPE

Future advances could be oriented to the enhancement of the system in adverse settings like when there is low light, weather disturbance, and occlusions. Real-time transactions can be facilitated through integration with

cloud-based databases and payment gateways to be carried out in a secure and scalable way. Multi-lane support and advanced vehicle tracking support can be also implemented as extensions of the system to be deployed on a large scale. Also, it is possible to implement state-of-the-art deep learning models and edge optimization algorithms that will enhance both the precision and processing time and make the system more flexible to the real-world environment.

REFERENCES

- [1] R. Janarthanan, P. Patel, D. N. Raj, and R. Divekar, "Improving Car Plate Recognition with Convolutional Neural Networks and Regular Expressions Correction," *3rd International Conference on Data Science and Information System, ICDSIS 2025*, 2025, doi: 10.1109/ICDSIS65355.2025.11070377.
- [2] N. K. Gunda *et al.*, "Few-Shot Lightweight License Plate Recognition in Complex Environments for Intelligent Transportation Systems," *IEEE Transactions on Intelligent Transportation Systems*, 2025, doi: 10.1109/TITS.2025.3591015.
- [3] S. Mala, H. R. Vidyashree, and K. Chanda, "Yolo model-based license plate extraction and toll generation for smart parking systems," *Proceedings - ICNEWS 2024: 2nd International Conference on Networking, Embedded and Wireless Systems: Wireless Technology - Building a Digital World*, 2024, doi: 10.1109/ICNEWS60873.2024.10730931.
- [4] "IEEE Xplore Full-Text PDF:" Accessed: Mar. 30, 2026. [Online]. Available: <https://ieeexplore.ieee.org/stamp/stamp.jsp?tp=&arnumber=10452589>
- [5] K. Anand, M. Navin Nath, and N. Naidu, "Virtual Toll Booth Based on Number Plate Recognition System Using Yolo V8 and Easy OCR," *2023 International Conference on Data Science, Agents and Artificial Intelligence, ICDSAAI 2023*, 2023, doi: 10.1109/ICDSAAI59313.2023.10452589.
- [6] N. S. Nareddy *et al.*, "Autonomous Number Plate Detection System for Vehicle Identification and Tracking," *Proceedings of 2024 2nd International Conference on Recent Trends in Microelectronics, Automation, Computing, and Communications Systems: Exploration and Blend of Emerging Technologies for Future Innovation, ICMACC 2024*, pp. 315–320, 2024, doi: 10.1109/ICMACC62921.2024.10894466.
- [7] M. K. J. Krishna, "NUMBER PLATE DETECTION FOR AUTOMATED TOLL PAYMENT SYSTEMS USING YOLO & CNN," *Journal of Nonlinear Analysis and Optimization*, vol. 16, p. 2025.
- [8] P. Saravanakumar¹, P. Durgarao², C. H. Deepika³, L. Vedan⁴, M. Saikumar⁵, and A. Prof, "Issue 12 www.jetir.org (ISSN-2349-5162)," *JETIR2412507 Journal of Emerging Technologies and Innovative Research*, vol. 11, 2024, Accessed: Mar. 30, 2026. [Online]. Available: www.jetir.org
- [9] M. M. K, M. Rayan Khan, H. Farooq Sheikh, I. Ahmed Khan, A. Professor, and C. Science, "Ai Based License Plate Detection," 2025, Accessed: Mar. 30, 2026. [Online]. Available: www.ijert.org
- [10] M. S. V Sarode, "Non Helmet and Number Plate Detection Patil Durvesh Sanjay 1 Dalal Yadnyesh Sachin 2 Patil Atharva Sahebrao 3 Patil Vishal Suresh 4," *IJSRD-International Journal for Scientific Research & Development*, vol. 12, pp. 2321–0613, 2024, Accessed: Mar. 30, 2026. [Online]. Available: www.ijrsrd.com

Cite this article as:

Bugatha Renuka and B.Ramamohan,"AI powered automatic toll payment system using Number Plate Recognition", *Proceedings of 13th international conference on Microelectronics, Circuits and Systems, Micro2026*,

Displayed as online on 23th June 2026.

Link: <http://actsoft.org/science/micro2026-pro/279-micro2026.pdf>

@Copyright to 'Applied Computer Technology', Kolkata, WB, India. Website: <https://actsoft.org>, Email: info@actsoft.org